



Christmas In October – Kansas City  
Design & Construction Guidelines  
Wheelchair Ramp

(June 2010)

The purpose of this document is to provide cost effective design and construction guidelines for the installation of wheelchair ramps. The layout of ramps will vary for each project due to a variety of factors, some of which may even prevent the installation. The factors affecting the layout include ADA recommendations, special user requirements, site restrictions, and neighborhood aesthetics.

ADA recommendations include the following,

Slope. It is recommended that the slope not exceed 1-1/2" per foot (1:8). One inch per foot (1:12) is the preferred slope. (5 to 7 degrees)

Width. The ramp should not be less than 36", however this is generally considered too narrow for wheelchairs, except for short ramps. Forty-eight inches is generally recommended where space permits. Thirty-nine and forty-two inch widths are common. Our guidelines use 48 inches.

Size of landings. The length of landings should not be less than 60 inches. For a 90 degree turn this would require a five by five foot landing.

Maximum Length. A straight sloped section shall not exceed 30 feet without a level landing for the user to rest.

Handrails. Handrails shall be provided on both sides of ramps that are more than six inches above grade. The height of the rails shall be between 34 and 39 inches. Thirty-six inches is the general recommended height. The railing should extend 12 inches beyond the end of the ramp. If the ramp is over 30 inches above grade then the sides must be enclosed with one or two intermediate side rails or balusters (opening space not more than four inches).

Initial height. The height of any lip confronting the wheelchair should not be greater than 1/2 inches. (The ramp should not be more than 1/2 inches below the door sill and above the outdoor entry point.)

Determine if there are any special requirements of the disabled resident that might affect the design. For instance, if the person has a disability that requires an arm or leg to extend out from the chair then the width of the ramp and/or the length of turns might need to be increased. If the resident is overweight or caretaker not

very strong an easier slope, and maybe even an intermediate level landing to rest, might be needed.

It is important that the installation not obstruct convenient access to the house by mail carriers and others including care providers, and that it be aesthetically compatible with the neighborhood.

The minimum allowable width for ramps is 36 inches; however, this is very restrictive for ramps over a few feet long. Forty eight inches with four stringers is the recommended width for longer ramps with handrails. This will provide ample space for caregivers to move alongside the chair if required, and will provide stringers on 16 inch centers to provide maximum support. A 42 inch width with three stringers is also acceptable, and may be preferred or even necessary due to site restrictions.

Ramp stringers should be 2x6 for unsupported spans less than 8 feet. Longer spans up to 10 feet should be 2x8s. See figure 3 for a table of maximum span lengths for various joist spacing. It is important to nail the side stringers and the headers to the support posts in addition to screws, as the nails will provide better sheer strength than the screws. Where necessary a 2x4 should be attached to the support post below the header on each side or between the posts to assure adequate support.

Although  $\frac{3}{4}$  inch exterior grade plywood is often used for the deck surface,  $\frac{5}{4}$  x6 deck board is recommended. The plywood will be slipperier when wet, not drain off water well and will be more prone to deterioration.  $\frac{5}{4}$  deck boards are  $5\frac{3}{4}$  inches wide. Leave  $\frac{1}{8}$  inch between boards to allow for drainage and expansion. So to estimate the number of boards required, divide the length of surface to be covered by 5.875. Order ten foot lengths (cut in half at site) for landings, and either eight or twelve foot lengths (cut in half or thirds at the site) for ramps. Two deck screws (suitable for pressure treated wood) per joist is sufficient to secure the boards.

Ramps are generally terminated by burying the stringers into the ground ahead of a solid surface. It is important that these stringers be suitable for ground contact. (Not all pressure treated lumber is suitable for ground contact.) In many situations it will be necessary to provide a solid surface (concrete or asphalt) at the end of the ramp to transition to another surface.

Begin the project by first determining if the site is suitable for the ramp.

Where and how will the ramp connect to the house?

Locate the outdoor end point for the ramp by driveway or sidewalk,

Determine the height from grade at the end point to the door sill or porch.

Determine the length of the ramp required to provide suitable slope (1:12 recommended, 1:8 maximum)

Assess impact of obstacles and grade changes

Locate any landings or turns required

To determine the required length of slope required, it is necessary to first determine the elevation change required from the entry point at the house to the termination point at a sidewalk or drive way. This can be determined by stretching a level string tightly from the entry point at the house to a vertical stick at the termination point for the ramp in the yard. (A string level should be used to be sure the string is level.) Then measure the distance from grade to the string to determine the required slope. (Note: If available, a laser level should be used to provide a more accurate measurement.)

It is recommended that the ramp slope be one inch for every foot of length (1:12 or 5 degrees). The maximum slope should not be greater than 1½ inches ever foot (1:8 or 7 degrees). Thirty six feet of sloped ramp would be recommended for a three foot drop in grade (36x12/12). If the user is capable of handling a slightly steeper slope a twenty four foot length would be acceptable with a 1:8 slope (36/1.5). To this length would need to be added to the length of any landings or turns. See figure Determining Length of Ramp for illustration of this method.

After the required length and location of turns are determined, it is necessary to determine the materials required. The following is a list of the basic materials to be used in the ramp constructions. All lumber shall be pressure treated and where required suitable for ground contact.

4x4 posts

2x6 strings, joists, headers and cross braces

5/4 x 6 deck boards (5 3/4 actual width plus 1/8 inch spacing)

12x12 precast concrete patio block footings for support posts

2x4 toe boards

5/4 x6 deck board as intermediate rail (between toe board and handrail)

3/8 x 3 1/2 galvanized bolts with flat washers to join headers

2" deck screws (deck boards to stringers)

2 1/2" deck screws (toe boards and rail boards to support posts)

3" deck screws (center stringers to headers and side stringers to posts)

16d galvanized nails (side stringers to headers and ramp to support posts)

Construction of the ramp can be divided among several teams. One or two volunteers can be cutting the lumber to the standard lengths as indicated in the section and plan views provided in this document. While two volunteers are working on assembly of the ramps, another team can be working on assembly of landings. Once the frame for the first section of ramps is set, then the frame for the landing can be attached, then the next section of ramp. Another team of volunteers can be working on installation of the deck boards and another team the handrails. Another team can be working on construction of steps if required. Crew sizes will be set by the difficulty of the task and the skills of the volunteers. Some tasks may only require a single volunteer, while others may need three or four to insure maximum efficiency. Some work, such as deck boards and landings, can be pre-cut and even preassembled off site to expedite the complete assembly.

The following is a list of basic tools used for ramp construction.

Circular saw (Chop saw would be very helpful for cutting deck boards)

Cordless drill/driver and battery charger

Hammer

Pencil

Level (pole level is very handy for setting 4x4 posts)

Tape measure

Chalk line

Speed square

Post hole digger if buried concrete footings are needed

Level laser or string and string level

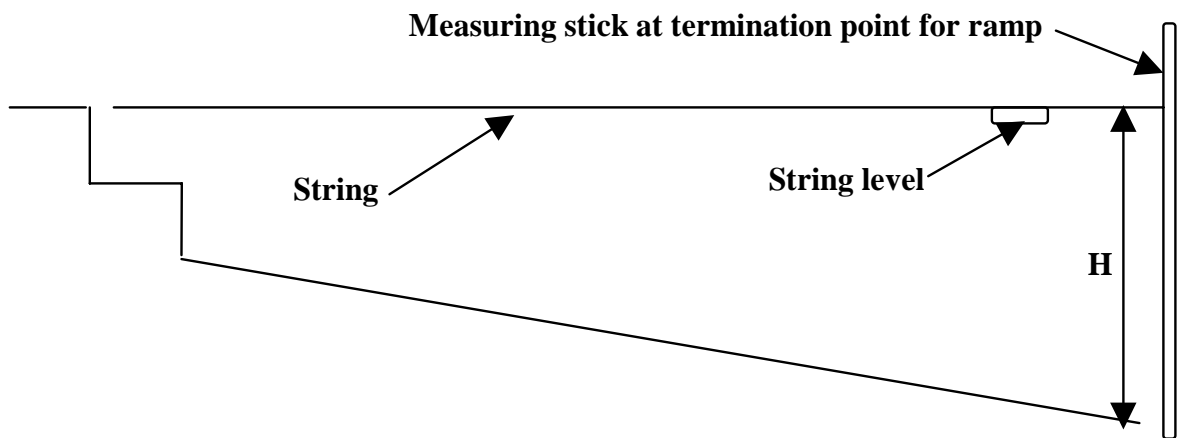

Recommended length of ramp in feet for 1:12 slope (5 degrees) = H in inches  
 Maximum length of ramp in feet for 1:8 slope (7 degrees) = H in inches / 1.5

(Example: If H=36" then the sloped sections of ramp should be between 24 and 36 feet long.)

(Note: If available a laser level should be used to provide a more accurate measurement.)

**Figure 1**  
**Determining Length of Ramp**

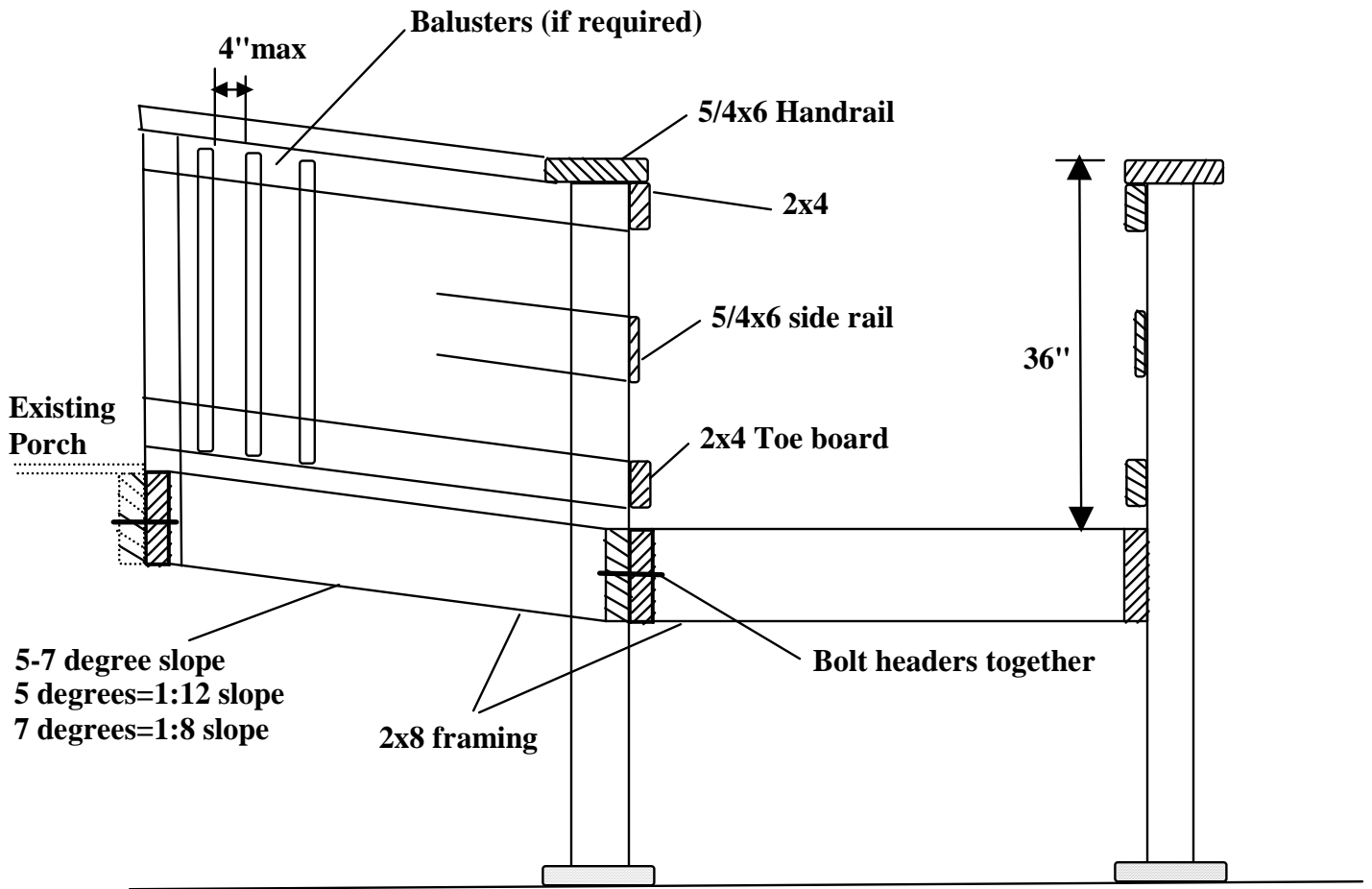

**Figure 2**  
**Ramp/Landing Cross Section**

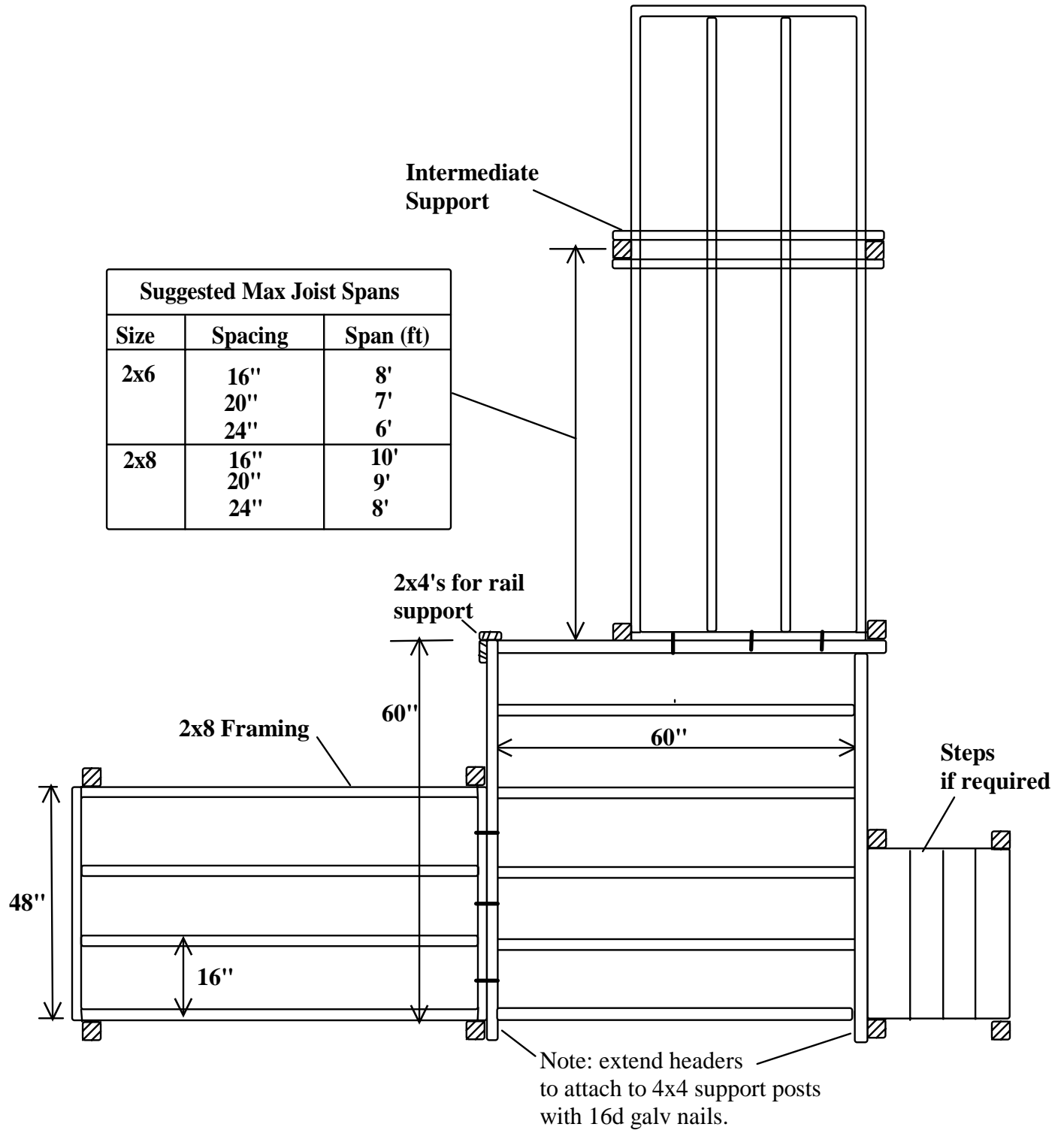

**Figure 3**  
**90 Degree Turn Landing**

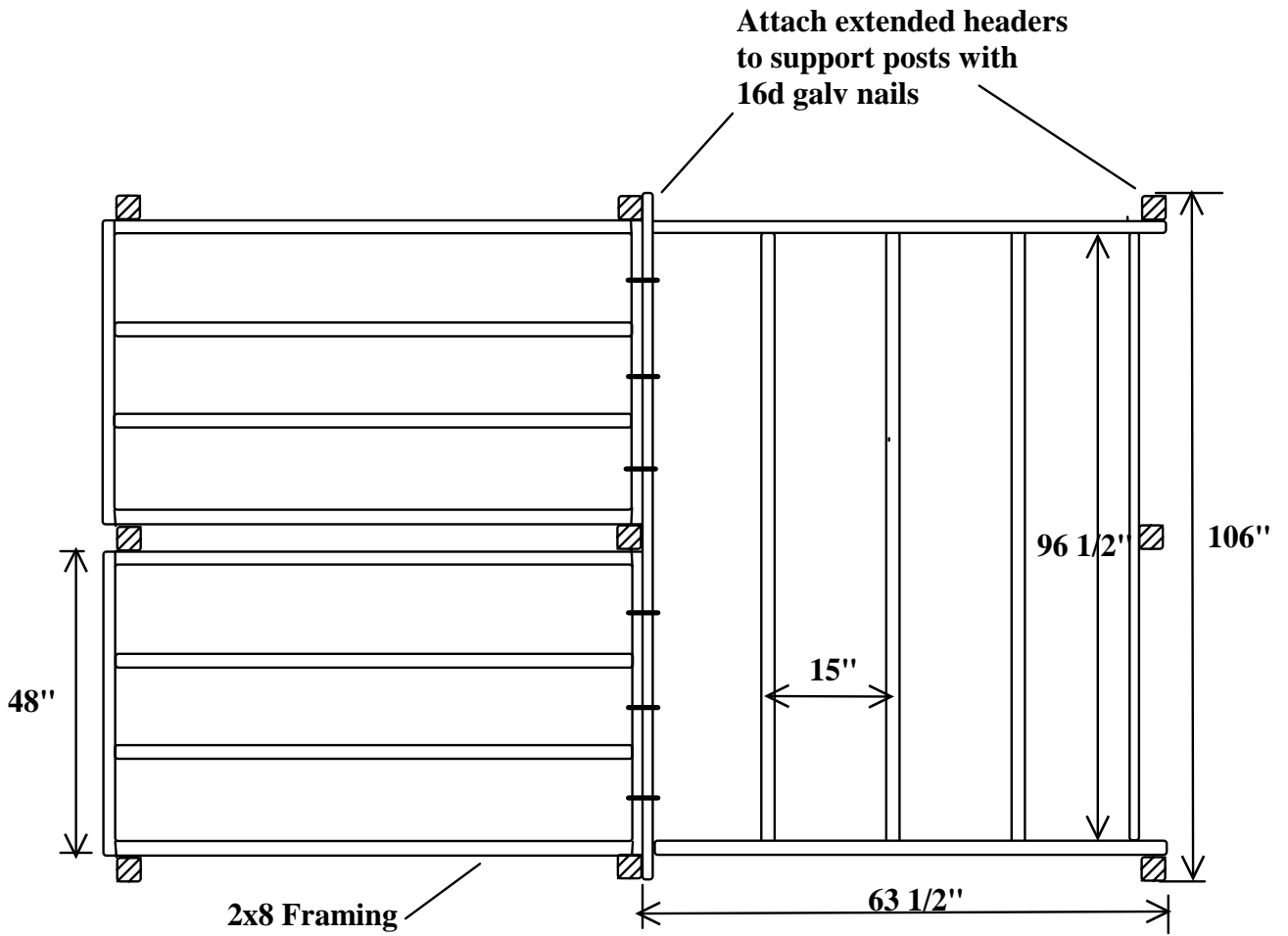

**Figure 4**  
**180 Turn Landing**

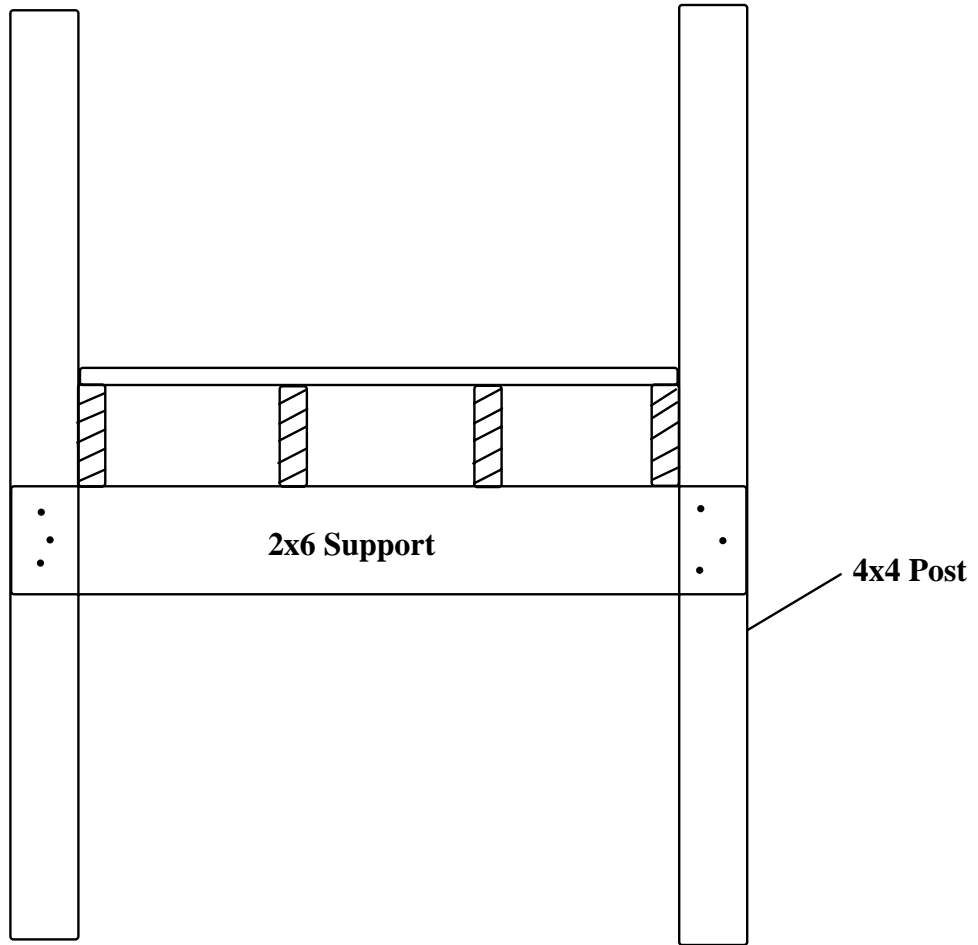

**Figure 5**  
**Intermediate Support**  
(Required for 2x6 spans over 10 feet)

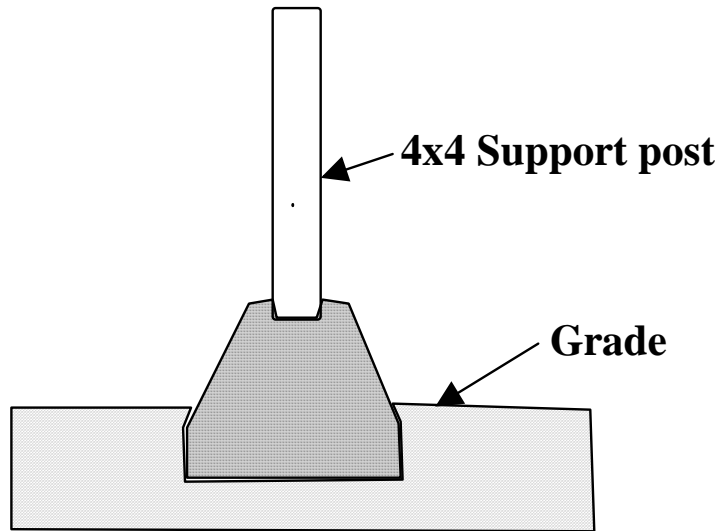

**Figure 6**  
**Precast Concrete Piers**

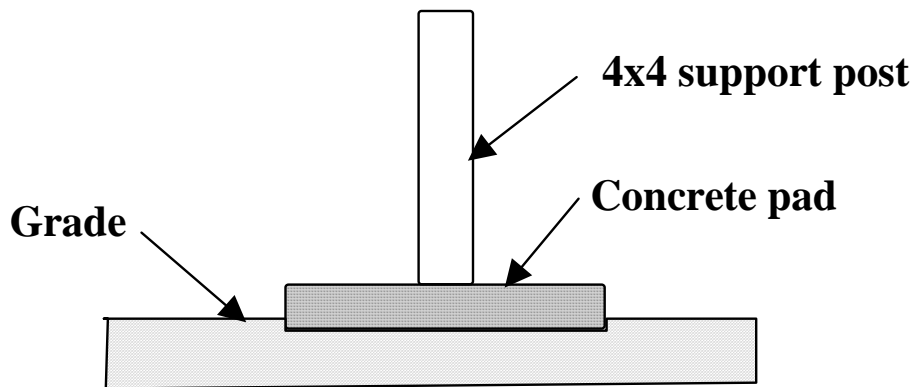

**Figure 7**  
**Post on Concrete Pad**

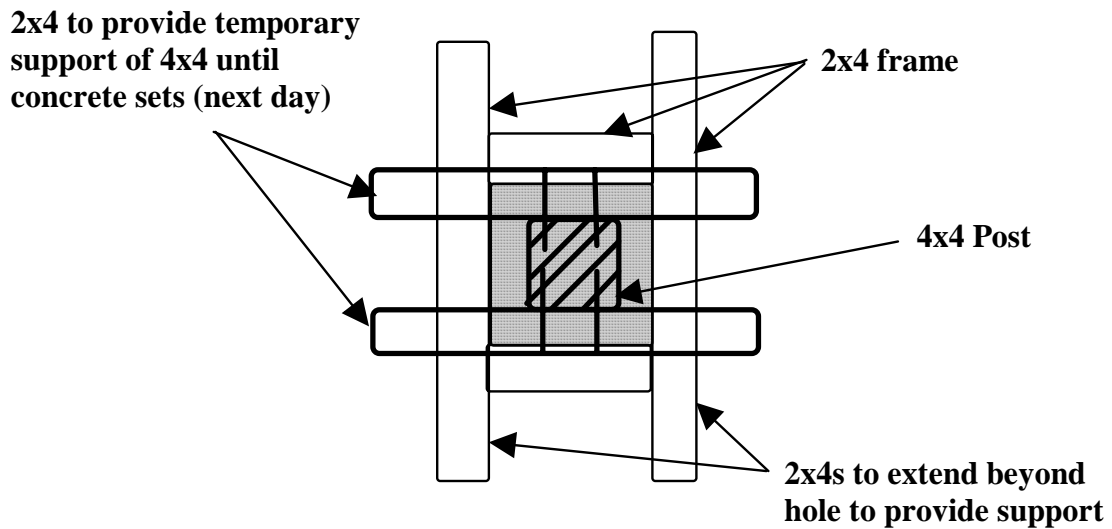
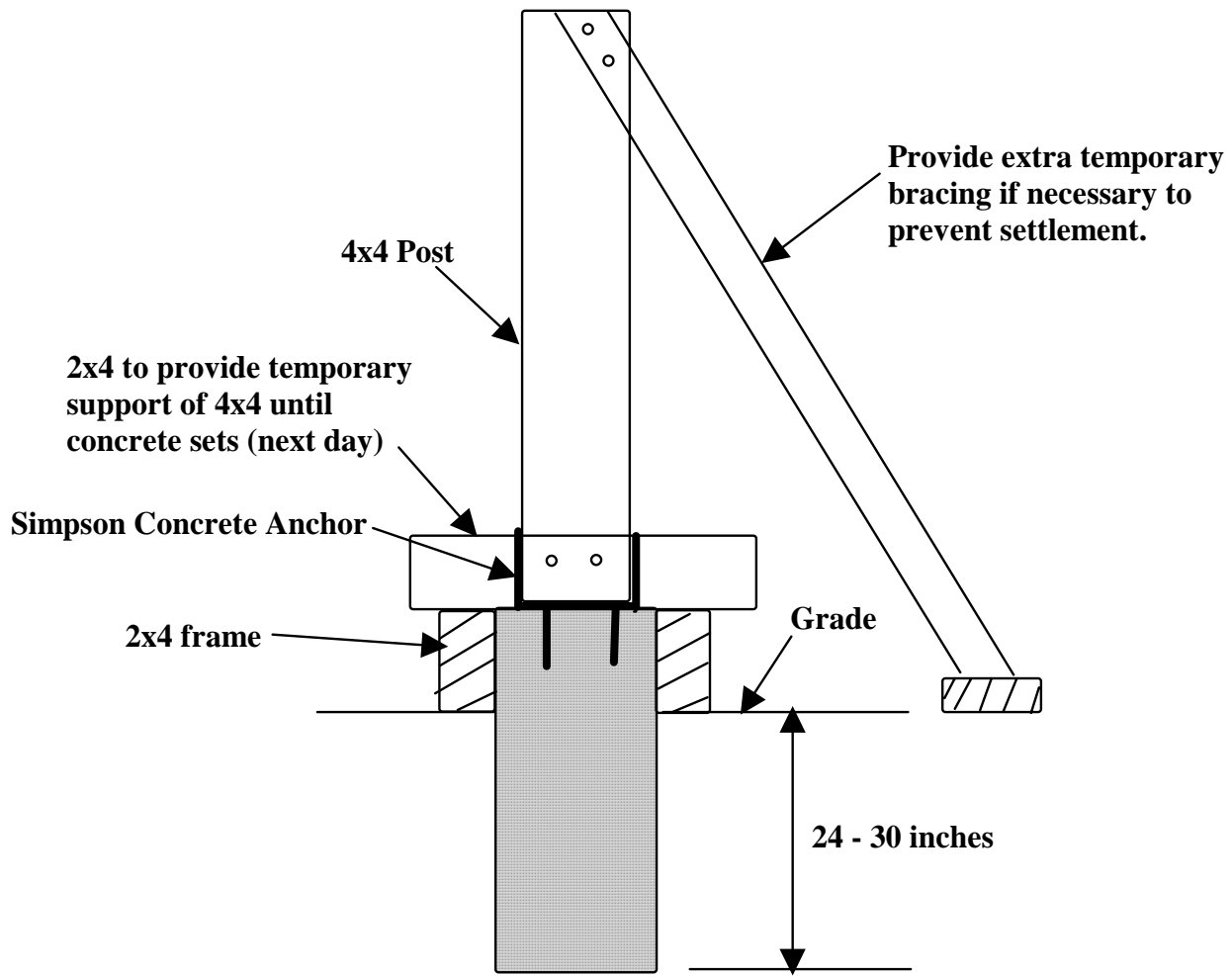

**Figure 8**  
**Concrete Foundation/Pier Construction**  
 (Where Required)

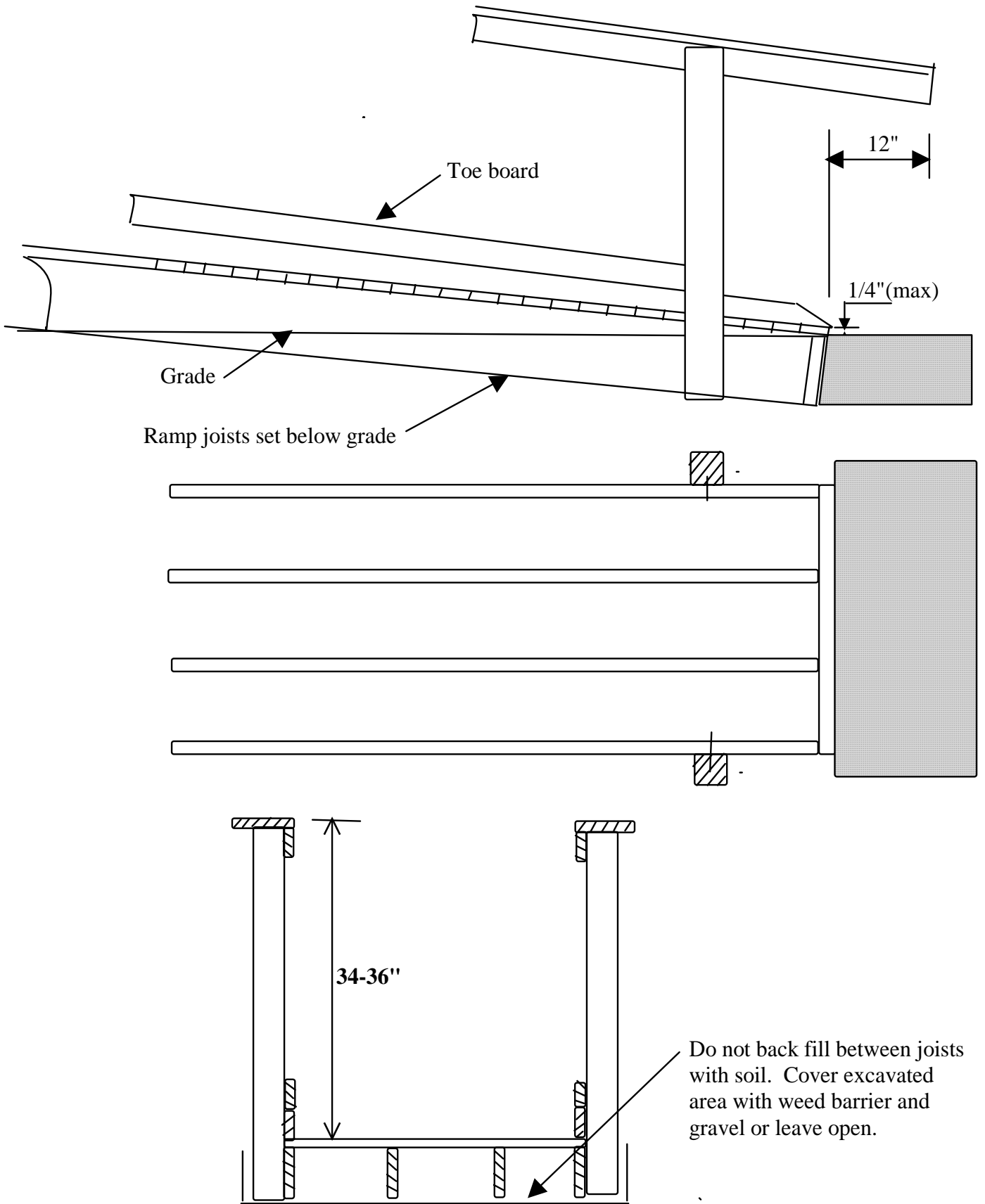

**Figure 9**  
**Ramp Gound Termination**  
**With Joists Below Grade**

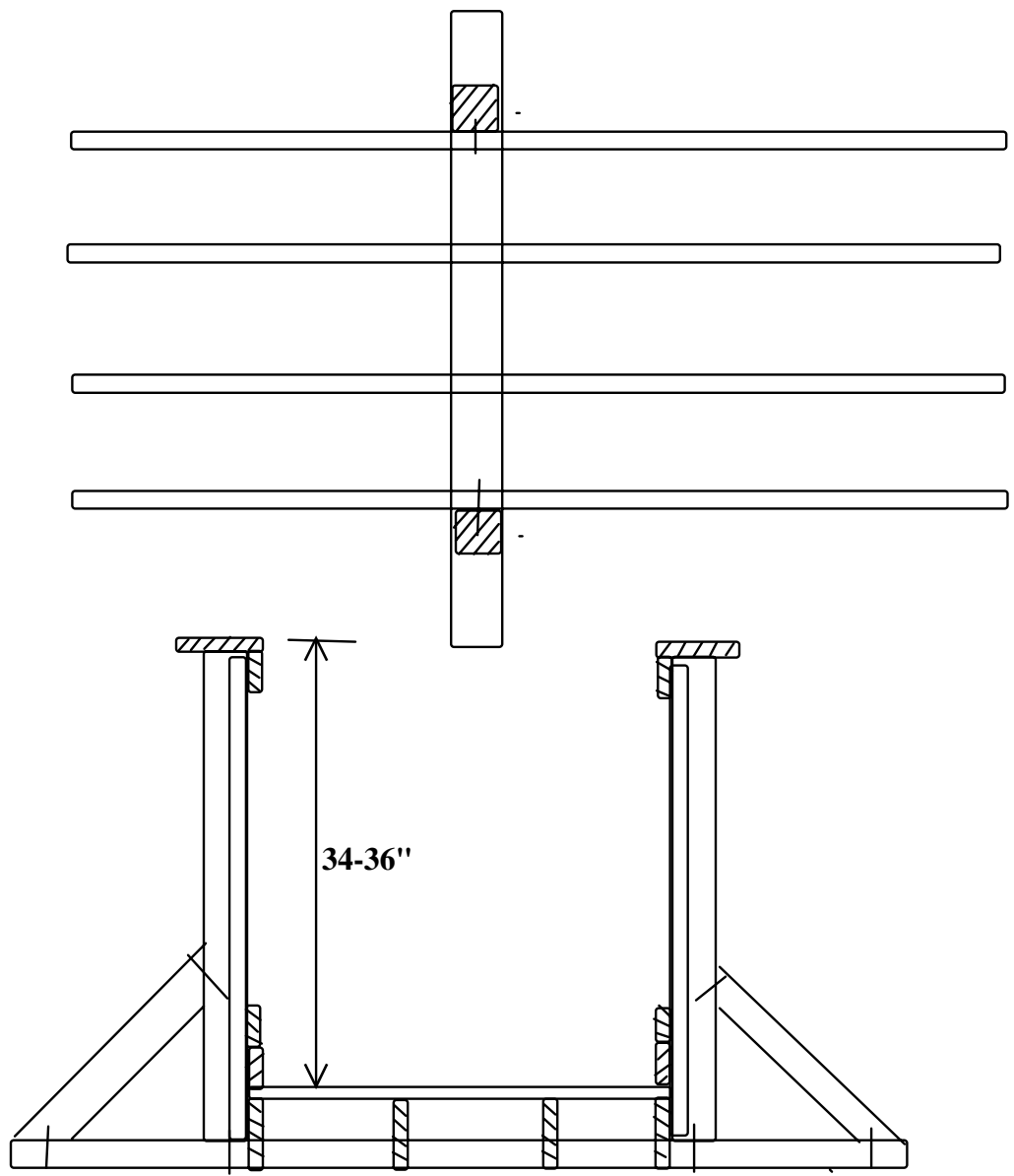
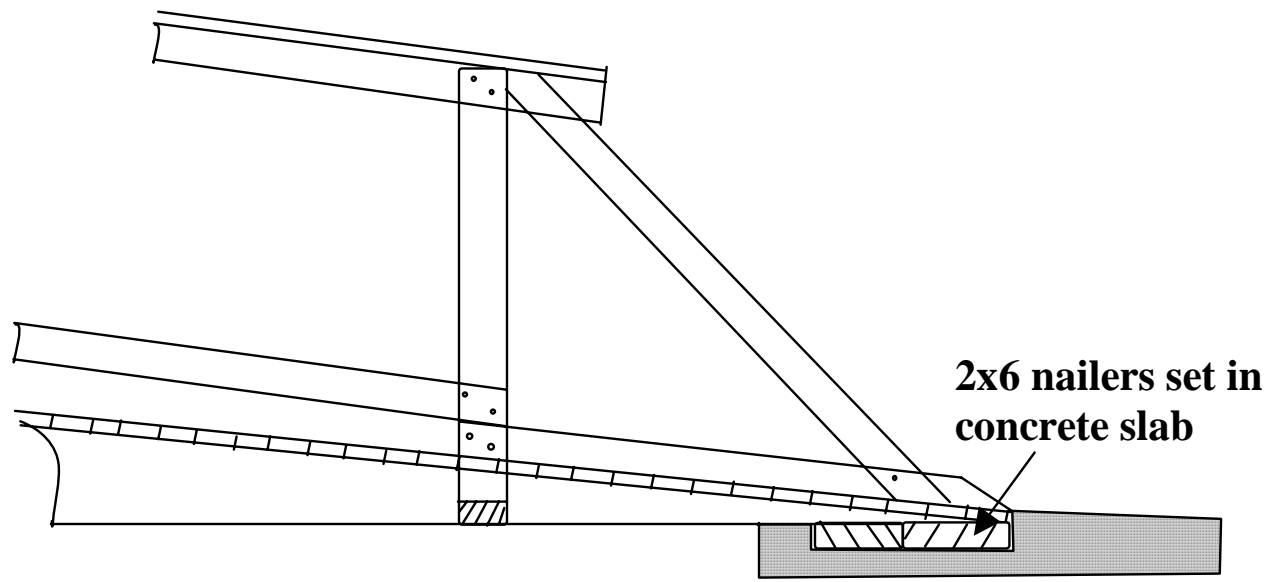

**Figure 10**  
**Ramp Gound Termination**